

Data sheet

iCombi® Pro 6-1/1 E/G



Capacity

- > 6 lengthwise insertion for 1/1 GN-Accessories
- > Removable standard racks with 68 mm insertion distance
- > Wide range of accessories for various cooking processes such as grilling, braising or baking
- > For use with 1/1, 1/2, 2/3, 1/3 GN accessories and optional baking standard accessories (400 x 600 mm)

Combi-steamer mode

- > Steam 30 °C – 130 °C
- > Convection 30 °C – 300 °C
- > Combination of steam and convection from 30 °C - 300 °C

Description

Intelligent, connectable cooking system with the operating modes poultry, meat, fish, egg dishes/desserts, side dishes/vegetables, baked goods and finishing as well as the cooking methods roasting, cooking, baking and grilling.

- > Combi-steamer in accordance with DIN 18866 (in manual mode).
- > For most cooking processes used in commercial kitchens.
- > For the use of steam and convection, individually, successively or together.

The following intelligent assistants are available:

Intelligent assistants

iDensityControl  iProductionManager  iCookingSuite  iCareSystem⁺ 

iDensityControl

iDensityControl is the intelligent climate management system in the iCombi Pro. Thanks to the interaction of sensors, high-performance heating system and live steam generator as well as its active dehumidification, the right cooking chamber climate is always available. The intelligent air turbulence ensures the best possible energy input into the food. This therefore ensures exceptional productivity with high food quality, uniformity and minimal energy consumption.

iCookingSuite

The iCookingSuite is the cooking intelligence in the iCombi Pro. Initially, the user selects the cooking path from 7 cooking modes and from 4 cooking methods to suit the food. The desired cooking result is also specified by the user. The unit suggests browning and cooking degree adjustments. Intelligent sensors recognise the size, quantity and condition of the food. Depending on the cooking progress, all important cooking parameters such as temperature, cooking chamber climate, air speed and cooking time are adjusted to the second. The desired result is achieved with the best possible quality and in the shortest possible time. If desired, you can interrupt the cooking process and adjust the cooking result. The user can switch to iProductionManager or manual mode at any time. With the iCookingSuite, time, raw products and energy can be easily saved and without extra control effort, with standardised food quality.

iProductionManager

The iProductionManager organises the production process intelligently and flexibly. This includes which products can be cooked together on different inserts, the optimal order of foods and the monitoring of the cooking process. The iProductionManager supports you with information on inserting or removing dishes. Depending on the cooking process, the vouchers (up to 2 per level) can be placed anywhere or can be aligned with a specific target time. The iProductionManager arranges the food sequence accordingly and automatically makes the correct settings. The user decides if the food is cooked in an energy-optimised or time-optimised manner. Simple monitoring activities are no longer necessary, and working time and energy are saved.

iCareSystem

The iCareSystem is the intelligent cleaning and descaling system in the iCombi Pro. It recognises the current degree of dirt and calcification and suggests the ideal cleaning level and chemical quantity from 9 cleaning programmes. The ultra-fast intermediate cleaning cleans the iCombi Pro in just 12 minutes, all cleaning programmes can also run unsupervised overnight. If desired, the cooking system will then switch off automatically. With a low consumption of phosphate-free care products, water and energy, the iCareSystem is particularly economical and environmentally friendly. This keeps the iCombi Pro hygienically clean without any manual work and at a minimal cost. Optionally also with chemical storage system for fully autonomous cleaning.

Unit description and functional features

Intelligent functions

- > Intelligent climate management with percentage-accurate humidity measurement, setting and control
- > The actual measured humidity in the cooking cabinet can be set and called up
- > Dynamic air circulation in the cooking cabinet thanks to 1 intelligently reversing high-performance fan wheel with 5 fan wheel speeds, intelligently controlled and manually programmable
- > Intelligent control of cooking paths with automatic adjustment of the cooking steps to achieve the defined desired result, e.g. browning and degree of doneness, safely and efficiently. Independent of the operator, size of the food and load quantity
- > Monitoring and calculation of browning to the second based on the Maillard reaction to reproduce optimum cooking results
- > Intervene in intelligent cooking paths or switch from iCookingSuite to iProductionManager for maximum flexibility
- > Intelligent cooking step for proofing baked goods
- > Individual, intuitive drag-and-drop programming of up to 1,200 cooking programmes with up to 30 steps.
- > Easy transfer of cooking programmes to other cooking systems thanks to secure cloud connection with ConnectedCooking or via USB stick
- > Automated, intelligent iProductionManager planning and control tool for the optimum organisation of multiple cooking processes and mixed loads. Automatic closure of planning gaps. Automatic time or energy optimisation of planning and target time cooking to start or finish cooking food at the same time. Full microwave power mode can be activated to minimise preparation times during peak periods.
- > Visual signalling of loading and unloading prompts using energy-saving LED lighting
- > Automatic resumption and optimum completion of a cooking process after power failures lasting less than 15 minutes
- > Intelligent cleaning system suggests cleaning programmes and the required amount of care products based on the degree of soiling of the cooking system
- > Display of the current cleaning status and descaling status
- > Intelligent control of the VarioSmoker (accessory) using cooking paths
- > Condensation and exhaust air bonnets (accessories) with situational adjustment of extraction performance and transmission of service messages.

Cooking functions

- > Effective steam generator for optimal steam performance even at low temperatures below 100 °C
- > Power Steam function: increased steam output can be selected for Asian applications
- > Integrated, maintenance-free grease separation system without additional grease filter
- > Cool-down function for rapid cooling of the cooking cabinet with selectable, additional rapid cooling by water injection
- > Core temperature probe with 6 measuring points and automatic error correction in the event of incorrect measurements. Optional positioning aid for soft or very small food (accessory)
- > Delta-T cooking for particularly gentle preparation with minimal cooking losses
- > Exact steaming, water volume adjustable in 4 levels in the temperature range from 30 °C - 260 °C for convection or a combination of steam and convection
- > Digital temperature display adjustable in °C or °F, display of set and actual values
- > Digital display of cooking cabinet humidity and time, display of set and actual values
- > Time format adjustable in 24-hour format or am/pm
- > 24-hour real time clock with automatic changeover from summer to winter time when connected to ConnectedCooking
- > Automatic start time preselection with adjustable date and time
- > Integrated hand shower with automatic return and switchable spray and single jet function
- > Energy-saving, long-lasting LED lighting in the cooking cabinet with high colour rendering for quick recognition of the cooking status
- > Free hotlines for questions regarding technology and application support (ChefLine)

Occupational and operational safety

- > Electronic safety temperature limiter for steam generator and hot air heater
- > Integrated fan wheel brake
- > Maximum cooking cabinet door touch temperature of 73 °C
- > Maximum cooking cabinet door touch temperature of 163 °F
- > Use of cleaning cartridges, when using the storage option: iCareSystem AutoDose for optimum work safety
- > HACCP data storage and output via USB or optional storage and management in the cloud-based networking solution ConnectedCooking
- > HACCP data storage and output via USB
- > Tested according to national and international standards for unattended operation
- > Gas appliances: H2 Ready - approved and certified (KIWA) for operation with gas mixtures containing up to 20 % hydrogen by volume
- > Maximum drawer height not higher than 1.6 m when using a RATIONAL underframe
- > Ergonomic door handle with right/left opening and slam function

Networking

- > Integrated, IP-protected Ethernet interface for wired connection to the cloud-based networking solution ConnectedCooking
- > Integrated WLAN interface for wireless connection to the cloud-based networking solution ConnectedCooking
- > Integrated USB interface for local data exchange
- > Central appliance management, recipe, shopping basket and programme management, HACCP data management, maintenance management via the cloud-based ConnectedCooking networking solution

Cleaning and care

- > Automatic cleaning and maintenance system for cooking cabinet and steam generator, independent of mains pressure
- > 9 cleaning programmes for unattended cleaning, even overnight, with automatic cleaning and descaling of the steam generator
- > Ultra-fast cleaning in just 12 minutes for virtually uninterrupted, hygienic production
- > Automatic switch-off function after cleaning to reduce energy consumption
- > Cleaning schedule to remind you of upcoming cleanings or to set a forced cleaning ensures compliance with cleaning specifications.
- > Automatic safety routine after power failure ensures a detergent-free cooking cabinet even after cleaning has been cancelled
- > Use of phosphate- and phosphorus-free cleaning agents in tabs and cartridges.
- > When using the iCareSystem storage option: provision of chemicals in cartridges for optimum work safety
- > Hygienic, flush-floor installation without feet for easy, safe cleaning

- > 3-pane cooking cabinet door with rear ventilation, special heat-reflecting coating and swivelling glass panes for easy cleaning
- > Material inside and outside stainless steel DIN 1.4301, seamless hygienic cooking cabinet with rounded corners and optimised air flow
- > Easy and safe external cleaning thanks to glass and stainless steel surfaces and protection against water jets from all directions thanks to IPX5 protection rating
- > Automatic cleaning can be monitored via the cloud-based ConnectedCooking networking solution

Operation

- > High-resolution 10.1" TFT colour display and capacitive touchscreen with self-explanatory symbols for simple, intuitive operation and control using sweep or swipe movements
- > Acoustic prompt and visual display when user intervention is required
- > Central dial with push function for intuitive selection and confirmation of entries
- > More than 55 languages can be set for the user interface and help function
- > Basic cooking preferences of the country-specific cuisine can be selected independently of the set appliance language. It is possible to select another country-specific cuisine
- > Specially customised cooking parameters for international or country-specific dishes can be selected and started independently of the set appliance language
- > Extensive search function in all cooking paths, application examples and settings
- > Context-sensitive help, which always displays the current help content for the displayed screen content
- > Start application examples from the help function
- > Simple selection of cooking paths via 7 operating modes from 4 cooking processes
- > Cockpit function for displaying information about the processes within a cooking path
- > Individualisation and control of user profiles and access rights to avoid operating errors
- > Interactive messages on cooking paths, prompts, intelligent functions and warnings with the Messenger
- > Optional: Completely autonomous cleaning to ensure hygiene requirements without cleaning effort and without daily handling of chemicals (option: iCareSystem AutoDose).

Installation, maintenance and environment

- > Professional installation by RATIONAL-certified technicians recommended
- > Fixed waste water connection permitted according to SVGW
- > Adaptation to the installation location (altitude above sea level) through automatic calibration
- > Operation without water softening system and without additional manual descaling possible
- > Installation flush with the floor and wall by connection in the base area*
- > Service diagnostics system with automatic display of service messages, self-test function for active checking of appliance functions
- > Remote diagnosis via ConnectedCooking by certified RATIONAL service partners
- > 2-year RATIONAL warranty incl. parts, labour and travel **.
- > Regular maintenance is recommended. Maintenance by RATIONAL service partners as recommended by the manufacturer
- > Energy efficiency tested and passed according to ENERGY STAR. Published under www.energystar.gov

* See installation or planner manual for details

** Conditions apply, see manufacturer's warranty declaration at www.rational-online.com

Options

- > Hinging rack and air baffle for baking standard accessories (400 x 600 mm)
- > Cooking chamber door with left-hinged opening
- > MarineLine – Marine design
- > SecurityLine – Safety/prison design
- > MobilityLine – mobile design
- > HeavyDutyLine – particularly resilient design
- > Integrated fat drain
- > Mobile oven rack package
- > Energy optimisation system connection
- > Connection to operations monitoring (potential-free contacts)
- > Control panel protection
- > Safety door lock
- > Lockable control panel
- > Integrated chemical storage system: iCareSystem AutoDose

Technical specifications

Dimensions and weight

Dimensions (W x H x D)	
Cooking system (carcass)	850 x 754 x 775 mm
Cooking system (total)	850 x 804 x 842 mm
Cooking system with packaging	935 x 960 x 955 mm
Maximum working height top shelf*	≤ 1,60 m

*when using a corresponding RATIONAL underframe

Weights	
Maximum loading quantity / insertion	15 kg
Maximum total feed quantity	30 kg
Weight of electrical appliance without packaging	101 kg
Weight of electrical appliance with packaging	120 kg
Weight of gas appliance without packaging	115 kg
Weight of gas appliance with packaging	134 kg

Connection requirements electric

Voltage 3 NAC 400 V	
Electrical connected loads	10.8 kW
Steam power	9 kW
Hot air output	10.25 kW
Protection	16 A
RCD type	F/B
Voltage 1 NAC 230 V	
Electrical connected loads	10.8 kW
Steam power	9 kW
Hot air output	10.25 kW
Protection	50 A
RCD type	F/B

Connection requirements gas

Liquid gas G31	
Total nominal thermal load	13 kW
Nominal thermal load steam mode	12 kW
Nominal thermal load convection mode	13 kW
Required connection flow pressure	25 – 57.5 mbar
LPG G30	
Total nominal thermal load	13.5 kW

Nominal thermal load steam mode	12.5 kW
Nominal thermal load convection mode	13.5 kW
Required connection flow pressure	25 – 57.5 mbar
Natural gas H G20	
Total nominal thermal load	13 kW
Nominal thermal load steam mode	12 kW
Nominal thermal load convection mode	13 kW
Required connection flow pressure	18 – 25 mbar

Gas supply/connection: 3/4"
Other gas types and voltages on request

Connection requirements gas

Voltage 1 NAC 230 V	
Connected loads gas	0.6 kW
Fuse	16 A
RCD model	F

Connection requirements water

Water inlet (pressure hose) respectively	3/4"
Water pressure (flow pressure) respectively	1.0 - 6.0 bar
Maximum flow rate per cooking system	12 l/min
Water outlet respectively	DN 50
Max. short-term waste water quantity	0.4 l/sec

Only use temperature-resistant waste water pipes

Connection conditions exhaust air and thermal load

Latent heat load	569 W
Sensible heat output	680 W
Noise level (electric)	55 dBA
Noise level (gas)	60 dBA

Connection requirements data

LAN data interface	RJ45
WiFi data interface	IEEE 802.11 a/g/n

Minimum clearances during installation

Minimum clearance	Left	Back	Right
Standard	50 mm	0 mm	50 mm

> Comprehensive technical information on kitchen planning and unit installation can be found in the planning manual or in the installation instructions on our business customer portal.

Installation conditions

- > If heat sources are acting on the left or right side of the unit, the clearance must be at least 350 mm.
- > Specific national and regional standards and regulations which concern the installation and operation of commercial cooking appliances must be complied with. The local standards and regulations for ventilation systems must be adhered to.
- > To use ConnectedCooking, a RJ45 network access point or the option to integrate into a WLAN (IEEE 802.11 a/g/n) must be provided on site. A data rate of at least 100 MB/s should be provided for optimal performance.

Certifications



NSF certification

iCombi Pro (LM100) and iCombi Classic (LM200) are NSF certified, as shown on the NSF list.

Technical drawing Electric

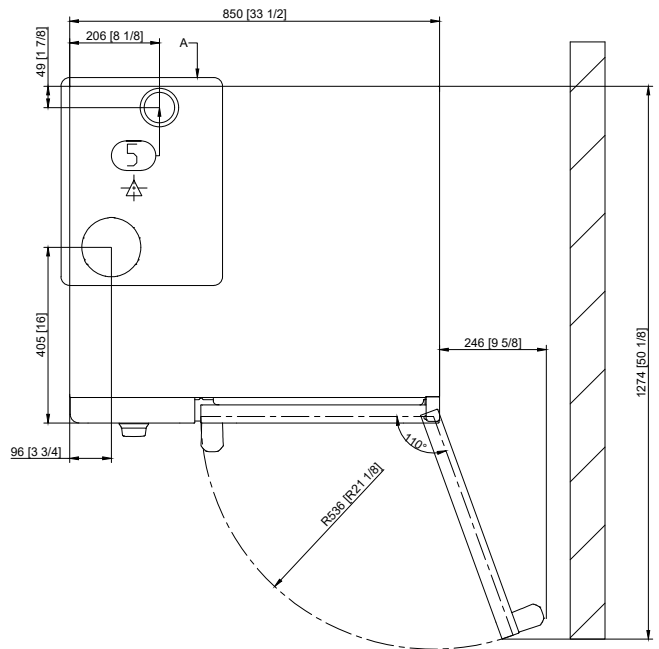
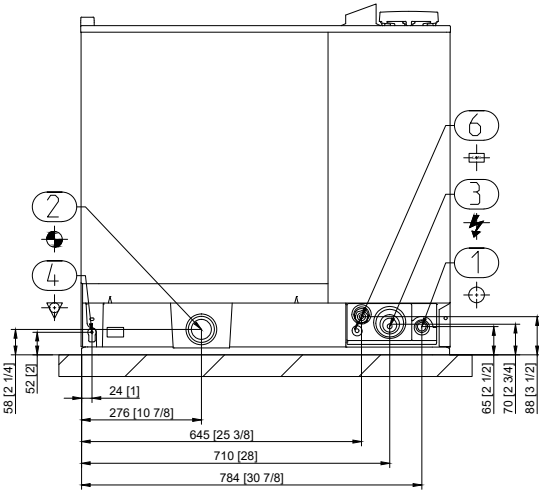
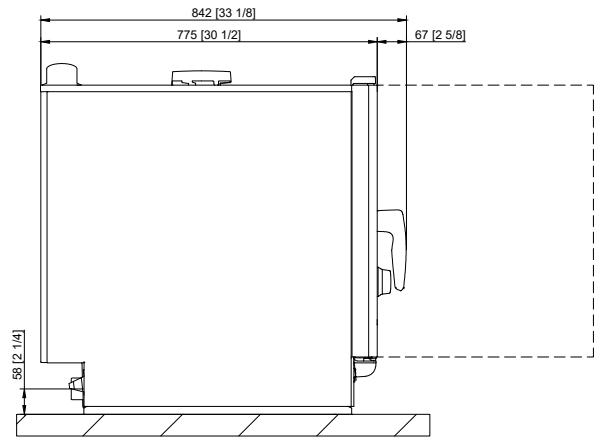
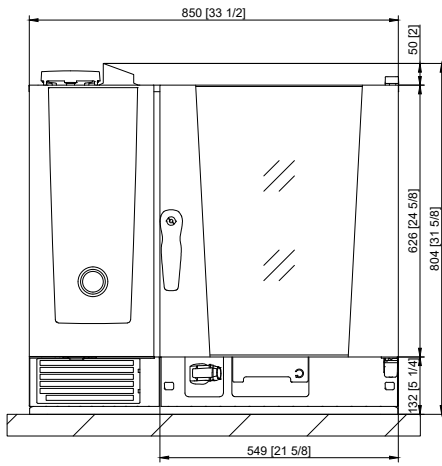

1	Water inlet
2	Water outlet
3	Electrical connection
4	Equipotential bonding
5	Ventilation pipe
6	Ethernet interface

Technical drawing Gas

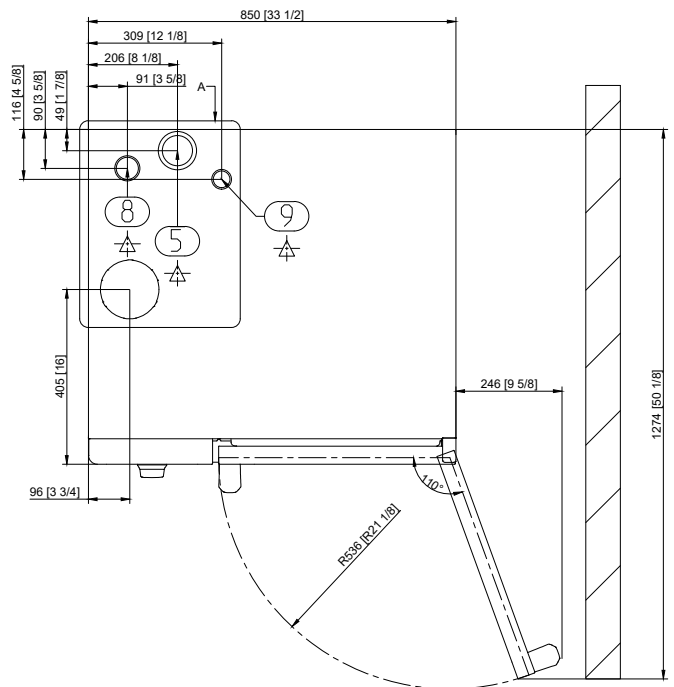
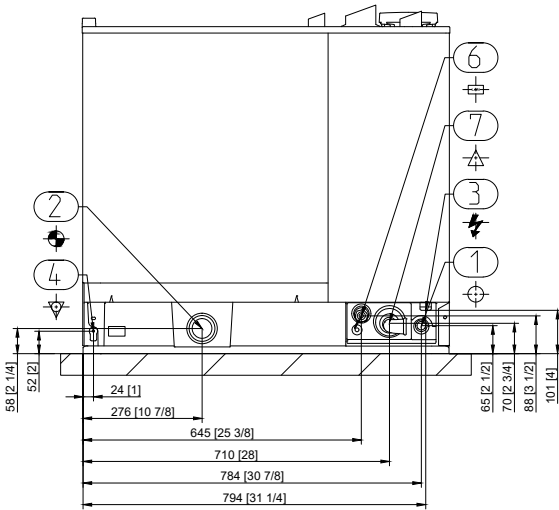
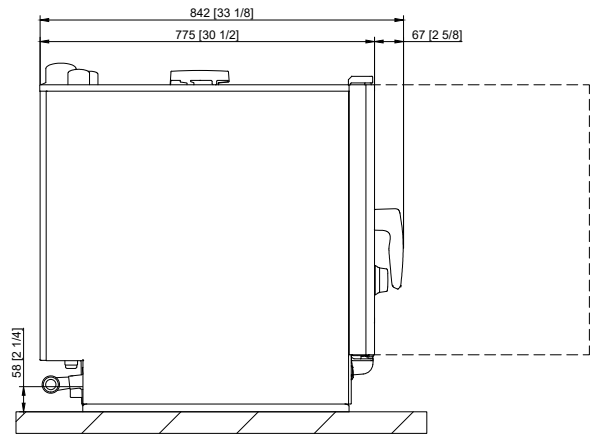
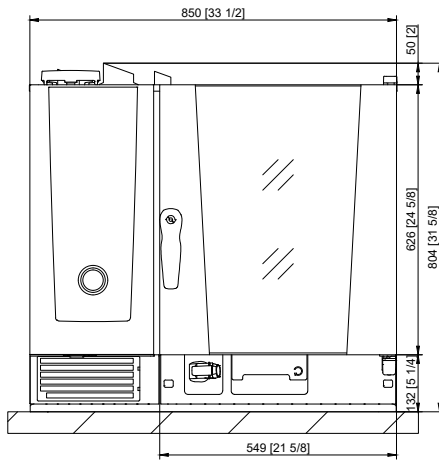

1	Water inlet
2	Water outlet
3	Electrical connection
4	Equipotential bonding
5	Ventilation pipe
6	Ethernet interface
7	Gas connection
8	Exhaust pipe gas (steam)
9	Exhaust pipe gas (hot air)

Accessories

Accessories	Article number
RATIONAL Active Green cleaner tabs - guarantees the best cleaning performance	
RATIONAL care tabs – effectively prevents limescale deposits	
Unit installation kit	
Wall mounting kit for 6-1/1 units	
Base frames in different designs - standard, with castors or fixable stainless steel feet	
Levelling kit to compensate for height differences and gradients in table and floor installation	
Mobile kit with rollers and height adjustment for floor installation	
Mobile oven rack trolleys and plate rack trolleys - for easy loading outside the cooking system	
Finishing systems for banquets	
Run-in rail for mobile oven racks and plate racks	
Transport trolleys for mobile oven rack trolleys and plate rack trolleys - standard and height adjustable	
Combi-Duo kit – to build a Combi-Duo for gas or electric units	
Heat shield - to install a unit next to a heat source, e.g. a grill	
Condensation breaker - to divert steam and vapours into existing exhaust systems	
Exhaust hood - only for electric units	
UltraVent Plus condensation hood – only for electric units	
UltraVent condensation hood – only for electric units	
Additional impact protection elements for HeavyDutyLine	
RATIONAL USB stick – for the safe transfer of cooking programmes and HACCP data	
VarioSmoker	

To achieve an optimal cooking result, you will find a wide range of cooking accessories and information on additional accessories in the accessories brochure, from your distributor or at www.rational-online.com

Planners	RATIONAL UK
	Unit 4 Titan Court, Laporte Way Portenway Business Park, Luton LU4 8EF Tel. +44 (0) 1582 480388 Fax +44 (0) 1582 485001 Email: info@rational-online.com Visit us on the internet: www.rational-online.com