

ORACRBXL

HIGH SPEED OVEN - ALL IN ONE. COMBI WAVE / HIGH SPEED OVEN - BOOSTED VERSION (COLOUR RED. RAL 3020)



 *High Speed Oven*  *Combi Wave*

Features



HIGH SPEED OVEN

An operating mode that simultaneously uses convection, microwave and impingement modes, with temperatures from 100°C to 300°C.



COMBI WAVE

In Combi Wave mode, the high speed oven can be used as a convection oven with temperatures from 30°C to 300°C, as a microwave oven with power up to 2000 W or with a combination of the two cooking methods to achieve results that always exceed expectations.



CONNECTED

Oracle connects free-of-charge to Lainox's Nabook plus portal via the standard- supply Wi-Fi and ethernet features giving you a 4.0 kitchen (find out more on nabookplus.cloud).



OOS - ORACLE ODORLESS SYSTEM

A labyrinth baffle catalyst filter containing platinum particles which help to reduce steam, odours and grease residue during cooking. The Oracle Odorless System does not require any cleaning or routine maintenance work. Its efficiency is always guaranteed.



FAST COOKING SYSTEM

Rely on our know-how with automatic, tried-and-tested recipes for high-speed cooking in High Speed Oven mode.



MICROWAVE COOKING SYSTEM

Rely on our know-how by using the automatic, tried-and-tested recipes for cooking in Combi Wave mode.



OWB - ORACLE WASHABLE BOX

A special Teflon oven chamber which can be removed and washed for the next round of cooking, making the cleaning procedure fast and cost-effective.

Capacity

Capacity Red - 36,4 lt.

Dimensions

Width	mm	577	inch	22.7
Depth	mm	797	inch	31.4
Height	mm	630	inch	24.8
Maximum outer width	mm	467	inch	18.4
Max exterior depth	mm	657	inch	25.9
Maximum exterior height	mm	630	inch	24.8
Packaging width	mm	990	inch	39.0
Packing depth	mm	770	inch	30.3
Packaging height	mm	800	inch	31.5
Net weight	kg	74	lbs	163.2
Gross weight	kg	86	lbs	189.6
Volume	m ³	0.29	ft ³	10.2
Packing volume	m ³	0.61	ft ³	21.5
Cooking compartment width	mm	460	inch	18.1
Cooking compartment depth	mm	440	inch	17.3
Cooking chamber height	mm	180	inch	7.1
Support base width	mm	536	inch	21.1
Support base depth	mm	646	inch	25.4
Power plug configuration	IEC 309			
Cable length	m	2	ft	6.56

Technical Data

High Speed Oven temperature	°C	100 / 300	°F	NaN
Temperatura Combi Wave	°C	30 / 300	°F	NaN

Power supply

Power supply voltage	3N-AC 400 V			
Electrical absorption	A	18		
Frequency	Hz	50		
Total electric power	kW	6		
Microwave	kW	2		
Impingement	kW	3		

Emissions

Latent heat	W	450
Sensitive heat	W	346
Noisiness	db	< 70

OPTIONAL ELECTRIC CONFIGURATION, WITHOUT EXTRA CHARGE - TO BE REQUESTED WHEN ORDERING

Option code	Connection plug (Plug provided)	Cable length (Provided - mt.)	Power supply voltage	Frequency Hz	Total electric power		Power output - kW		Country
					kW	A	Impingement	Microwave	
OR380	Not included	2	3N-AC 380 V	60	6	18	3	2	KSA/KO/LATAM
OR3230	Not included	2	3-AC 230 V	60	6	18	3	2	LATAM
OR3208	Not included	2	3-AC 208 V	60	6	20	3	2	LATAM
OR32305	Not included	2	3-AC 230 V	50	6	18	3	2	
OR3093	IEC 309 - 32 A	2	1N-AC 230 V	50	6	26	3	2	EU

AUS Australia

EU Europe

KO South Korea

KSA Kingdom of Saudi Arabia

LATAM Latin America

UK United Kingdom

HOW TO USE

- Combi Wave. - MCS (Microwave Cooking System) automatic cooking system for Italian and international recipes, including the history, ingredients, cooking accessories, procedure and automatic cooking program. - Manual mode with three instant start cooking methods: convection, microwave or combined convection + microwave.
- High Speed Oven. - FCS (Fast Cooking System) automatic cooking system for Italian and international recipes, including the history, ingredients, cooking accessories, method and automatic cooking program. - Manual mode with instant start.
- Programmable mode: possibility of programming and storing a recipe with its cooking procedures in automatic sequence.

CONNECTIVITY

- Nabook Plus - Thanks to the Cloud feature, it is possible to access Nabook Plus, the virtual kitchen assistant (read more on nabookplus.cloud, free registration).
- Direct access to the recipe database with download option (patented).
- Synchronisation of multiple Oracle ovens connected to the same account (patented).
- HACCP Monitoring.
- Remote diagnosis through the Nabook plus portal by the LAINOX Service Center.
- Possibility to download recipes from the Nabook Plus portal based on country.
- Possibility to run automatic software updates on multiple devices simultaneously.
- Wi-Fi connection. Compatible with IEEE 802.11g (2.4 GHz) standard.
- Automatic software update notification system.
- Recipe creation including ingredients with procedure and photo.

CONTROL MECHANISMS

- USB connection to download HACCP data, update software and upload/download cooking recipes.
- Possibility of choosing the fan speed.
- Automatic fan speed for High Speed Oven mode.

STRUCTURAL CHARACTERISTICS

- Pull-down door with ergonomic handle.
- The door slides under the oven cooking surface, allowing the food to be removed safely without the risk of burns.
- Integrated catalyst filter for operation without hood.
- Perfectly smooth room.

OPERATION

- High-definition 7-inch capacitive LCD color screen with choice of "Touch Screen" functions.
- Organisation of recipes in folders with preview, giving each folder its own name.
- Display that can be configured based on the needs of the user, bringing forward the programmes used most.
- Oracle coach. Virtual assistant that provides advice on using and informs when maintenance is needed.
- There are about 30 recipes available in Oracle and a growing number of alternative ones are available via access to the Nabook plus portal. Each recipe has been tested to guarantee best results.
- Rapid cooling of the cooking chamber with open door.
- Possibility of preheating the cooking chamber up to 300°C.
- Starting an automatic "One Touch" cooking.
- User interface with a choice of 29 languages.

SAFETY FEATURES

- Self-diagnosis with smart error viewing.
- Door open/closed electronic sensor.
- Compliant with the IEC60335-1, IEC60335-2-90 and EMC international standards.
- Max 65°C external temperature on the door panel.

CLEANING AND MAINTENANCE

- Easy external cleaning thanks to the perfectly smooth surfaces and IPX3 protection rating against water spray.
- OWB - Oracle Washable Box. special removable and washable box chamber.

INSTALLATION AND ENVIRONMENT

- Quality ISO 9001 / Safety ISO 45001 / Environmental ISO 14001 certification.
- Product recycling rate: 90%.
- 100% recyclable packaging.

STANDARD EQUIPMENT

- Wi-Fi connection. Compatible with IEEE 802.11g (2.4GHz) standard
- USB connection
- Ethernet connection
- Anodized aluminum alloy plate
- Oracle Washable Box
- Oracle Washable Door Cover. Removable and washable inner door protection
- Aluminium peel (570 x 420 x 100 mm)
- Electric plug
- Power cable - 2 m

OPTIONAL TO BE REQUESTED WHEN ORDERING

- OR380:** Optional electric configuration, without extra charge. 3N-AC 380-400 V - 60 Hz. Plug not included
- OR3230:** Optional electric configuration, without extra charge. 3-AC 230 V - 60 Hz. Plug not included
- OR3208:** Optional electric configuration, without extra charge. 3-AC 208 V - 60 Hz. Plug not included
- OR32305:** Optional electric configuration, without extra charge. 3-AC 230 V - 50 Hz. Plug not included
- OR3093:** Optional electric configuration, without extra charge. 1N-AC 230 V - 50 Hz. Plug included (IEC 309 - 32 A)
- SOWBHDX:** Extra charge for Oracle Washable Box Heavy Duty version OWBHDX. Replaces the standard model

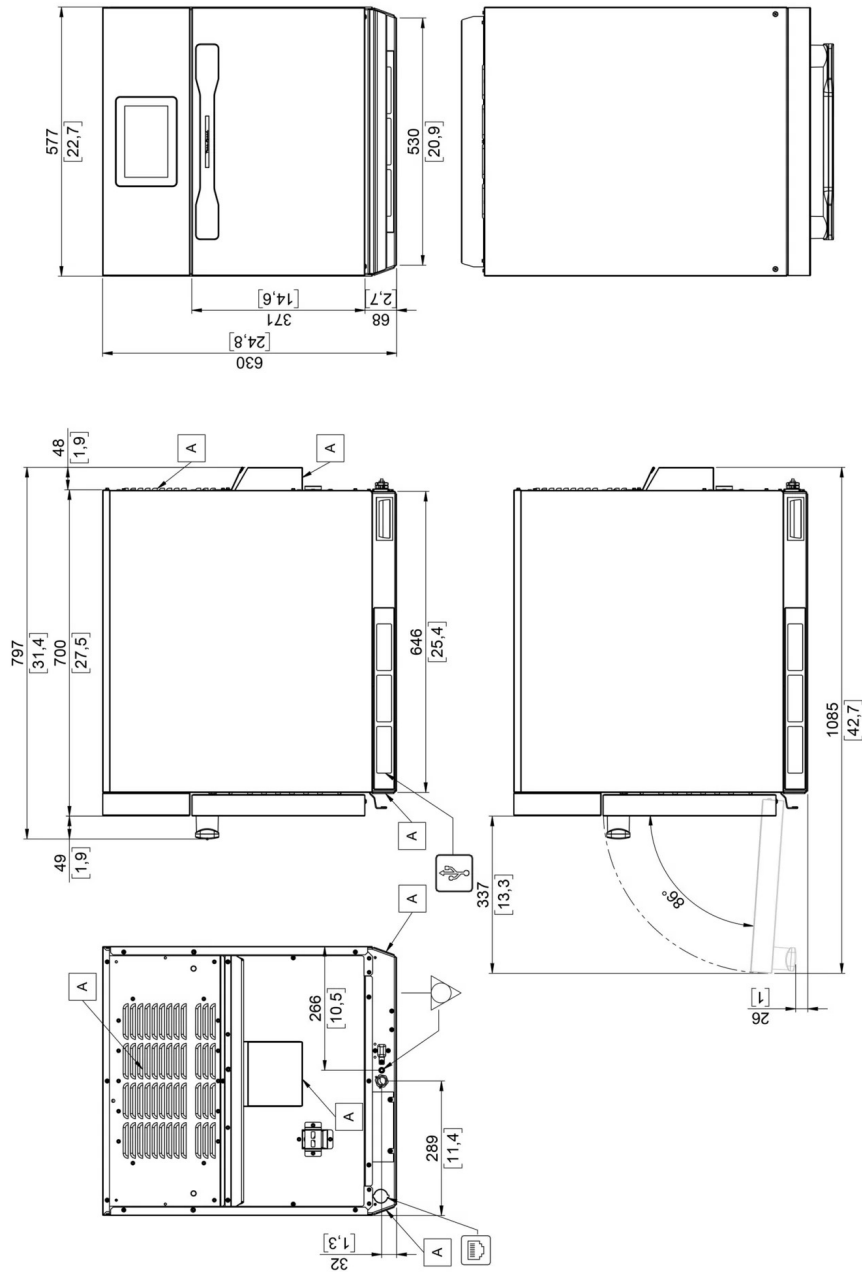

Dimensions: Millimeters [inches]

A	Technical compartment cooling air intake	
	Equipotential connection	
	USB connection	
	Ethernet connection	

The data reported in this document is to be considered non-binding. The company reserves the right to make changes at any time, without prior notice



LAINOX ALI Group Srl
 Via Schiaparelli 15
 Z.I. S. Giacomo di Veglia
 31029 Vittorio Veneto (TV) - Italy

Tel +39 0438 91110
 Fax +39 0438 912300
 lainox@lainox.com
 www.lainox.com

