



HJA-PLUS-M120

Class A charcoal ovens incorporate a hydraulic door retention system to optimize the chef's maneuvers. They have an upper tempering area that can be closed with the available accessory and a range of optional auxiliary tables.

Los hornos de carbón vegetal Clase A incorporan un sistema hidráulico de retención de puerta para optimizar las maniobras del cocinero. Disponen de una area de templado superior que puede cerrarse con el accesorio disponible y una gama de mesas auxiliares opcionales.

HJA-PLUS-M120



Recommended for ± Recomendado para ±	120 dinners 120 comensales
Fire up time Tiempo de encendido	35 min average 35 min aprox.
Charcoal consumption per service Consumo de carbón por servicio	15.43 to 17.63 lb 7 a 8 kg
Production per hour Producción por hora	192 lb average 90 kg aprox.
Broiling temperature Temperatura de braseado	482 a 662 °F 250 a 350 °C
Grill rack capacity in Gn trays Capacidad bandejas GN (por parrilla)	2xGN1/1
Flue gas mass flow Caudal másico de humos	0.54 oz/s 15,39 g/s
Exhaust rate Capacidad de extracción	3500 m³/h 3500 m³/h
Net weight Peso neto	817,9 lb 371 Kg

INCLUDED ACCESSORIES ACCESORIOS INCLUIDOS

GRILL RACK MEASUREMENTS MEDIDAS PARRILLA

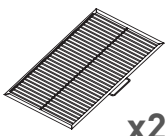

x2

Inox grill rack / Ref. [240025](#)
Parrilla inox / Ref. [240025](#)

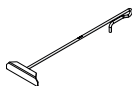

Poker / Ref. [0427INOX](#)
Atizador / Ref. [0427INOX](#)



Jospers tongs / Ref. [0423](#)
Pinzas Jospers / Ref. [0423](#)

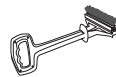

Metallic brush / Ref. [8224](#)
Cepillo metálico / Ref. [8224](#)

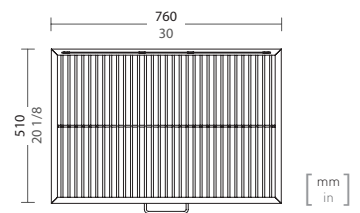

* All Jospers products work exclusively with charcoal.
Todos los productos Jospers funcionan exclusivamente con carbón vegetal.

* The NSF certification refers to the equipment and not to the accessories described in this document.
La certificación NSF hace referencia exclusivamente a los equipos y no a los accesorios descritos en este documento.





OPTIONAL CONFIGURATIONS & ACCESSORIES
 CONFIGURACIONES Y ACCESORIOS OPCIONALES



HJA-PLUS-M120-HC

HC - HOT CABINET / Ref. [HC-45](#)

HC - ARMARIO ATEMPERADOR / Ref. [HC-45](#)



HJA-PLUS-M120-T

T - TABLE / Ref. [200008](#)

T - MESA / Ref. [200008](#)



HJA-PLUS-M120-TD

TD - TABLE WITH DRAWER / Ref. [200009](#)

TD - MESA CON CAJÓN / Ref. [200009](#)

INSTALLATION
 INSTALACIÓN

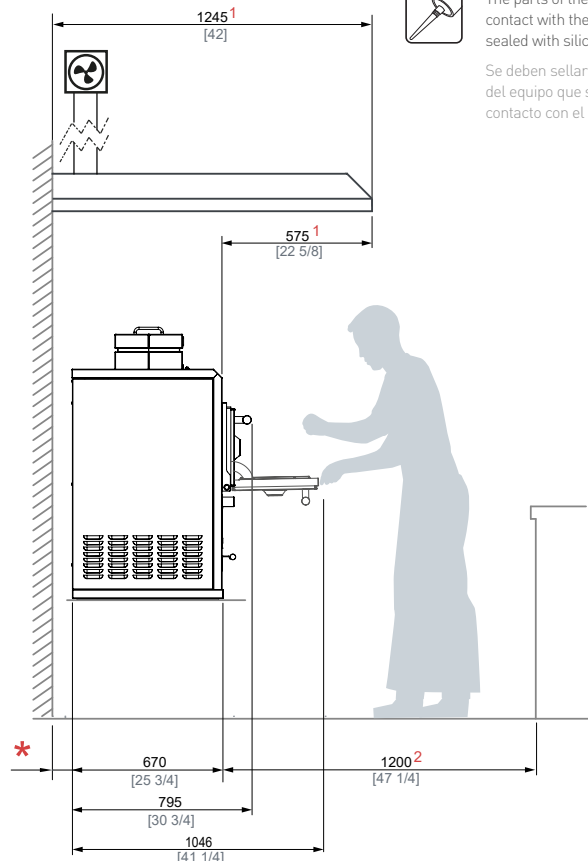
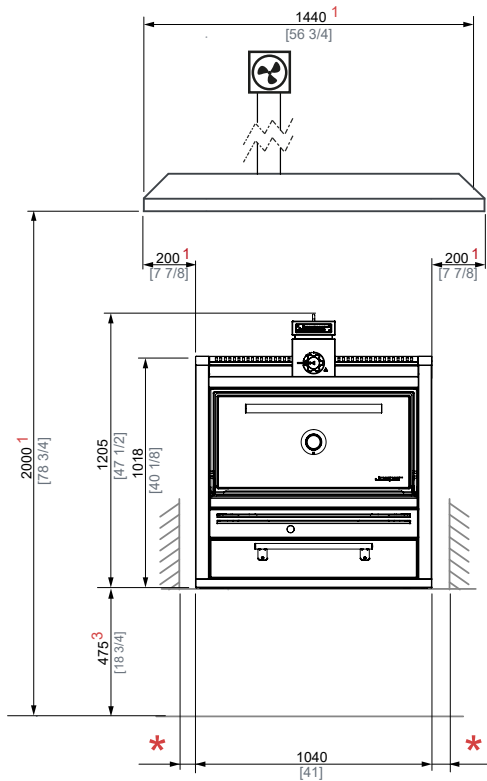

The parts of the equipment that are in contact with the lower cabinet must be sealed with silicone.

Se deben sellar con silicona las partes del equipo que se encuentran en contacto con el mueble inferior.

* MINIMUM DISTANCE TO FLAMMABLE ELEMENTS DISTANCIA MÍNIMA A ELEMENTOS INFLAMABLES	12 in	300 mm
* MINIMUM DISTANCE TO NON-FLAMMABLE ELEMENTS DISTANCIA MÍNIMA A ELEMENTOS NO INFLAMABLES	4 in	100 mm

- 1 RECOMMENDED HOOD'S MINIMUM DIMENSIONS
MEDIDAS MÍNIMAS RECOMENDADAS DE LA CAMPANA EXTRACTORA.
- 2 RECOMMENDED CHEF'S WORKING SPACE
ESPACIO RECOMENDADO DE TRABAJO PARA EL CHEF.
- 3 RECOMMENDED HEIGHT TO INSTALL THE OVEN WITHOUT TABLE
ALTURA RECOMENDADA DE INSTALACIÓN DEL HORNO SIN MESA

Ed. 0602 - Jospser reserves the right to make modifications to catalogues, pricelists and promotional material according to the development and improvements applied to its equipment.
 Jospser se reserva el derecho a realizar modificaciones en los catálogos, tarifas y material de divulgación según evolución y mejora de sus equipos.